

# UPS24 application instruction

## Function

In some applications a supply to system parts is necessary even during a supply breakdown. You maybe have to save machine run time data or system parameters when a supply breakdown occurs. If you use a short message unit you might even have to send a SMS containing the breakdown information. For all these and many other applications you can use the UPS24 to secure the power supply throughout the breakdown.

The UPS24 (Uninterruptable Power Supply 24V) offers a supply voltage of 24VDC, with an AC adapter of 24VDC, without interruption.

## Description

### Mounting

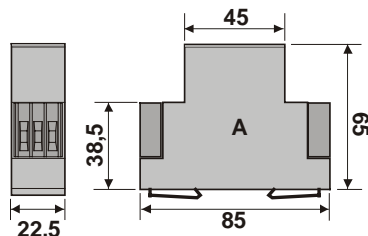

The UPS24 switches from a current of 24VDC from the mains to a storage-battery voltage, simultaneously there is a electronic charger available for the storage-battery (accumulator). The electronic is placed within a 22,5mm wide plastic box for DIN rail mounting.

The accumulator (Akku-Pack) is placed outside of the UPS24 and is connected directly to the UPS24. For easy installation this component is also ready for DIN rail mounting. The accumulator has short ended leads, so you have to place it next to the UPS24.

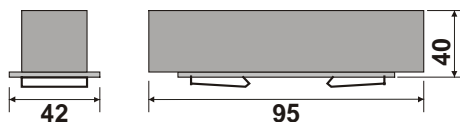

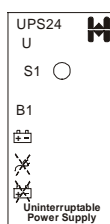

### Front panel with displays and control elements



On the front side of the UPS24 you can find five LED and one button.

The LED are hidden behind the front panel, so you can just guess where they are by symbols on the front panel.

The button just juts out a few millimetres. That way an unintentional activation and a damage during installation can be avoided.

Element	Function
U	external supply available
S1	button for switching on the voltage output
B1	status display B1
	accumulator active
	no external supply available or too little voltage
	voltage breakdown at the accumulator

### Wiring

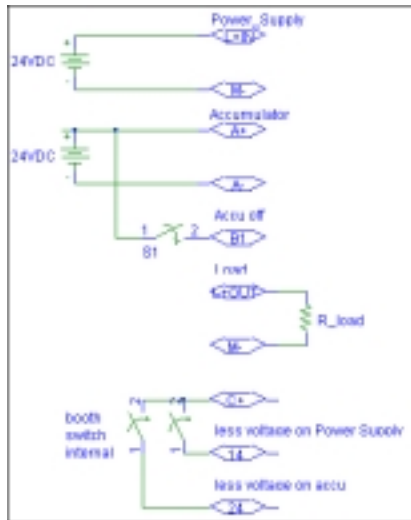

The figure on the left shows the provided wiring.

Terminals "M-" and "A-" are connected inside of UPS24 and have the same level. Pay attention to this, if you want to disconnect the accumulator from the load with input "B1" and a external potential has to be injected here.

The supply from an external AC adapter has to be connected with terminals „L+IN" and "M-".

For the connection of the accumulator use terminals "A+" and "A-".

Wire those devices which need an interrupt free supply with terminals "L+OUT" and "M-".

Use terminals "C+", "14" and "24" for supply status

messages or accumulator status.

If you want to disable the supply by the accumulator, you have to connect 24VDC with terminal "B1".

Terminal	Description
L+IN	voltage input, external supply connect the output of a 24VDC adapter to this terminal.
M-	reference potential
A+	positive pole of the accumulator
A-	negative pole of the accumulator
B1	input to disable the accumulator supply
L+OUT	voltage output
M-	reference potential
C+	common terminal for both output signals
14	output signal terminal 14 voltage supply too little or breakdown
24	output signal terminal 24 accumulator voltage near breakdown

## Accumulator (storage-battery)



If a breakdown of the external 24VDC supply occurs the accumulator will maintain the power supply. The switch happens automatically and without interruption.

With continuing life-span, the capacity of the accumulator also sinks. This is very strongly influenced by the ambient temperature, the environmental conditions and the load cycle. Therefore you can give no exact statement about the waste graph. Because of safety reasons it is recommended to test the accumulator once a year. From experience you should change the accumulator every five years.

If the AKKU-PACK doesn't meet your desired expectations, you can connect a different accumulator to the UPS24. To avoid problems refer to the technical informations for accumulator loading and power rating of the UPS24. You can use any NiCd and NiMH accumulator with capacities between 50mAh and 500mAh.

## Testing the accumulator

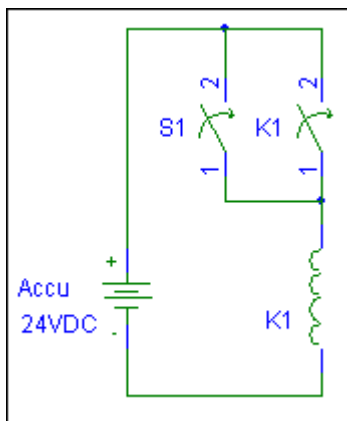

Use a very easy connection to find out about the capacity of the accumulator. Take a look at the figure on the left.

S1 is a button or a jumper and K1 is a 24VDC-relay (coil voltage between 10 and 50mA).

To startup active S1 briefly. In this period of time, the coil of the relay will be passed through by power and K1 brings the circuit to a self-hold state.

Now just the time must only be measured.

The capacity of the accumulator can now be calculated approximatively with the following formula:

$$\text{capacity in mAh} = t/(R \cdot 150)$$

t time in seconds (relay activated)

R coil resistance

Please note that the capacity of the accumulator is also influenced by the load. The less the resistance of the relay is, the less is the accumulator capacity. This effect cannot be influenced.

The advantage of this circuit is the deep discharge protection of the accumulator, because K1 falls if the accumulator voltage falls below a certain value. Note that the relay falls at the latest at a voltage of 8VDC below the holding voltage. Maybe it is necessary to connect two relays serially to get this effect.

## Function

### Accumulator load

The loading of the accumulator happens independent. For example, if the supply falls below 20V, the accumulator will be activated and simultaneously loaded.

To make this possible, the UPS24 has an own voltage increase circuit with current and voltage limiting.

## Switch from AC mains supply to accumulator supply

If the external supply falls below 20VDC, the accumulator will be activated. Because of possible jumpers the device will only switch back to AC mains supply if the external supply reaches 22VDC again.

## Status message accumulator voltage

The discharging graph of a NiCd-accumulator is very flat, only when the capacity comes near an end it steeps. Now it depends on the current taken out how quick the voltage falls. There is one status LED and one status output to detect this instant. Both status signals become active at an accumulator voltage between 18VDC and 22VDC.

If the voltage falls below 18VDC at the accumulator, the accumulator service will be disabled in order to avoid a deep discharge.

## Activate accumulator service

In some cases you could have to activate the accumulator manually, for example if the UPS24 has been just connected and no external supply is available. Activate the accumulator with button S1 at the front side of the UPS24.

The accumulator will not be active if the voltage is below 22VDC.

## Disable accumulator service

You can save accumulator capacity by setting input „B1“. This is very useful if breakdowns occur more often and the accumulator cannot be charged within the available time.

## Status messages

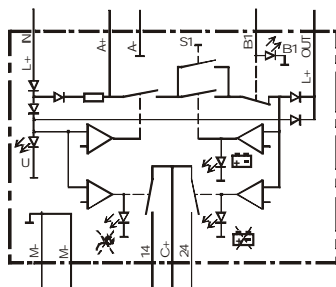

Message	Function
U	external supply available Note: There is no information about the level of external supply.
B1	status display B1 If input B1 is activated, the status message will become active. Note: The display will be active very briefly (0,1s) if you disable the accumulator service.
	accumulator active The output will be supplied by the accumulator.
	No external supply available or too little voltage A failure of the external supply will be displayed here.
	accumulator voltage breakdown The display becomes active shortly before the breakdown occurs.
Terminal 14	The connection C+ at 14 is simultaneously active with
Terminal 24	The connection C+ at 24 is simultaneously active with

## Technical information

Data	UPS24	Accumulator
Supply voltage	24VDC	24VDC
Supply voltage range	18VDC < U <sub>in</sub> < 30VDC	---
Nominal current drain	< 25mA	---
Accumulator type	---	NiCd
Rated capacity	---	110mAh
Operating temperature	+0°C < temp < +60°C	+0°C < temp < +45°C
Storage temperature	-30°C < temp < +70°C	-30°C < temp < +50°C
Switchover voltage from AC mains supply to accumulator supply ("L+IN" - "M-")	20VDC +/-1V	---
Switchover voltage from accumulator supply to AC mains supply ("L+IN" - "M-")	22VDC +/-1V	---
Accumulator deep discharge protection ("A+" - "A-")	18VDC +/-0,5V	---
Accumulator minimum voltage ("A+" - "A-")	22VDC +/-1V	---
Charging current for the accumulator (you can find the typical charging graph below)	("A+" - "A-") < ("L+IN" - "M-")? --> [("L+IN" - "M-") - ("A+" - "A-")]/400  ("A+" - "A-") < 28V? --> ~9mA	---
Switching voltage terminal C+ to 14	0,5VDC < U < 50VDC 0,5VAC < U < 40VAC	---
Switching voltage terminal C+ to 24	0,5VDC < U < 50VDC 0,5VAC < U < 40VAC	---
Switching current terminal C+ to 14	0,1mADC < U < 200mADC 0,1mAAC < U < 150mAAC	---
Switching current terminal C+ to 24	0,1mADC < U < 200mADC 0,1mAAC < U < 150mAAC	---
Mounting	EN50022 sym. DIN-rail 35mm	EN50022 sym. DIN-rail 35mm
Screw-type (tightening torque)	Pozidrive No. 1 (0,6-0,8Nm) Philips M2,5 (0,6-0,8Nm) Slotted 4mm (0,6-0,8Nm)	---
Weight	90g	170g
Dimensions (B*H*T)	22,5*85*65mm	42*95*40mm

**Typical accumulator charging graph**

**Charging**

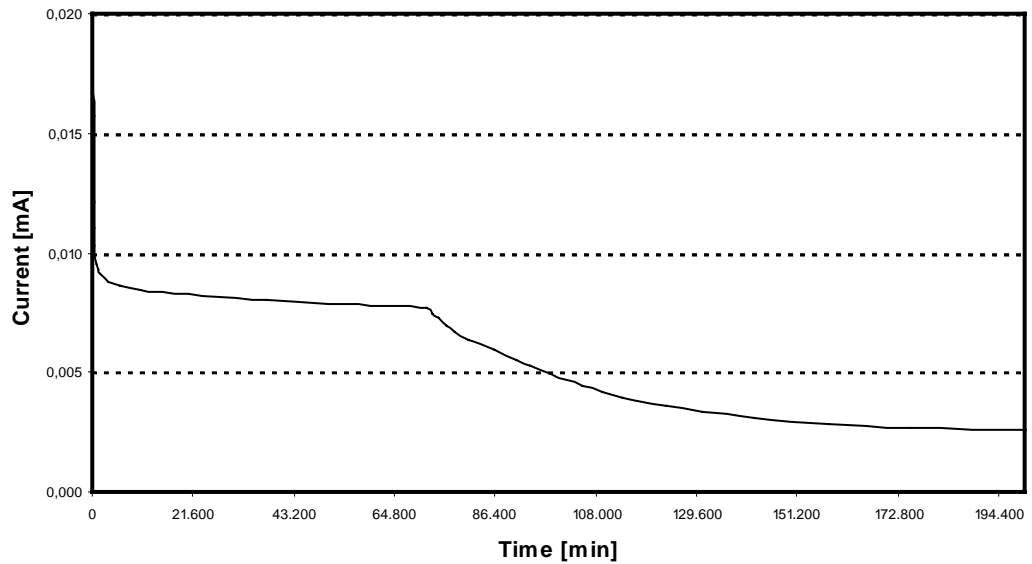

**Typical accumulator discharging graph**

Circuit diagram see Testing the accumulator. K1 = JW2SN-DC24V, Rspule= 1k065 Ohm (connect two relay coils serially), Rgesamt=2k3 Ohm.

**Discharging**

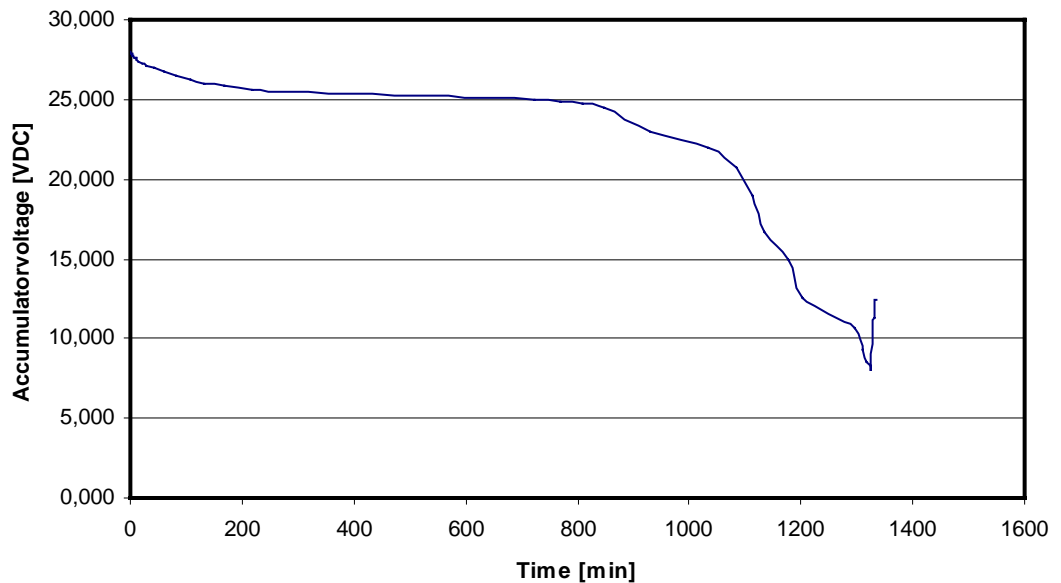

After the relays fall the accumulator voltage will rise. Accumulator capacity:  $(1300 \cdot 60) / (2300 \cdot 150) = 0,226 \text{mAh}$ . In fact it is a little lower but these numbers are sufficient for testing.

---

# Content

UPS24 APPLICATION INSTRUCTION .....	1
FUNCTION.....	1
DESCRIPTION.....	1
Mounting.....	1
Front panel with displays and control elements.....	1
Wiring .....	2
Accumulator (storage-battery).....	3
Testing the accumulator.....	3
Function.....	3
Technical information.....	5
CONTENT.....	7

Copyright 2003 HIQUEL GmbH, Bairisch Kölldorf 266, A-8344 Bad Gleichenberg

This manual is subject to copyright law. All rights are reserved.

Great care has been taken in the creation of the text, illustrations and program examples in this manual. Neither HIQUEL, their authors nor their interpreters may be held responsible for any errors herein, nor can they be held responsible or liable for consequences arising from any errors herein.

This manual may not be copied in part or whole in any form including electronic media without the written consent of Hiquel. Neither may it be transferred in any other language suitable for machines or data processing facilities. Also rights for reproduction through lecture, radio or television transmission are reserved.  
This documentation and the accompanying software is copyrighted by Hiquel.