

ANU/ANI

overview

- ◆ supply voltage 24V~
- ◆ feedback contact for manual or automatic mode
- ◆ protection against incorrect connection
- ◆ short circuit protection
- ◆ LED indicator proportional to output level
- ◆ 22.5mm DIN rail mount housing



Description:

ANU/ANI are used with automatic control systems (BMS, PLC, PC) that provide a 0-10V or 0-20mA signal for controlling variables such as temperature, speed, position etc.

In automatic mode ("Auto") the analogue signal from the control system (terminals YR & L) is re-transmitted to the controlled device (ratio 1:1).

In manual mode ("Manu") the analogue signal from the control system is isolated and the ANU/ANI inject a signal (terminals Y &) which can be adjusted from 0 to 10V or 0-20mA by the potentiometer.

The switch position (mode) can be monitored externally on terminals S1 - S2 (feed-back contact).

The brightness of the LED "Y" is proportional to the output signal level.

The output is short circuit protected.

specification

supply voltage variation	nominal voltage +20% / -15%
frequency range	48 - 63 Hz
duty cycle	100%
nominal current	24V~/35mA 24V=/11mA
contact material	silver alloy
switch	S1-S2 28V~/2A
current consumption	max. I_r 10V _{DC} 2mA
screws	pozidrive 1
screw tightening torque	0,6...0,8Nm
operating conditions	-20 to +60 °C non condensing

ANU

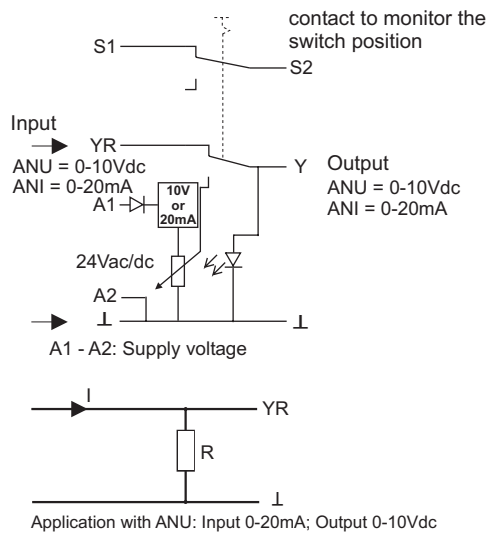

Current input with external resistor is possible.
 z.B.: 0-20mA and R = 500 Ohm
 terminal YR to terminal L = 0 - 10V

ordering information

part no	supply	output	relay type	HIQUEL	housing type
ANU	24V~ = < 1VA	0-10V=	-	-	B
ANI	24V~ = < 1VA	0-20mA=	-	-	B

